

CARTER (FX 300)

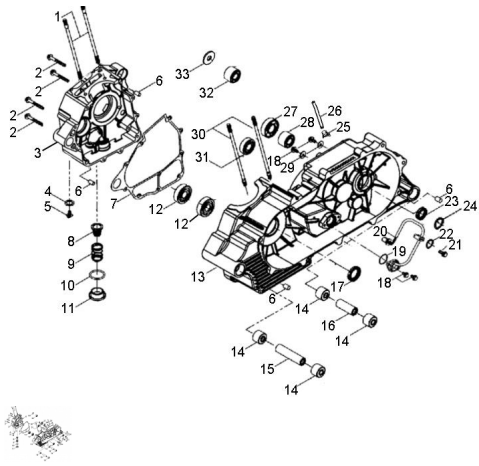

Rating: Not Rated Yet

Price:

Variant price modifier:

Base price with tax:

Price with discount:

Salesprice with discount:

Sales price:

Sales price without tax:

Discount:

Tax amount:

[Ask a question about this product](#)

Description	Ref.	Título	Código
	1		62-91001
	2	TORNILLO M6 X 25 X 1	62-96000
	3		62-11101
	4		62-94101
	5	TORNILLO	62-96003

Ref.	Título	Código
		M12 X 15 X 1,25
6	PERNO GUIA	62-94301
7	JUNTA	62-11191
8	TORNILLO FILTRO	62-15421
9	RESORTE FILTRO	62-15426
10	O-RING 34,3	62-93210
11	TAPON DRENAJE ACEITE	62-11334
12		62-96100
13		62-11201
14	BUJE	62-96400
15		62-11150
16		62-11151
17	RETEN 27 X 42	62-96500
18	TORNILLO M6 X 25 X 1	62-96000
19	O-RING 25,7 X 1,9	62-93212
20		62-35759
21	TORNILLO M6 X 25 X 1	62-96000
22		62-94101
23	RETEN 27 X 42	62-96500
24	ANILLO SE GURIDAD 25	62-94511
25		62-94515
26	TUBO FLEXIBLE	62-94408
27		62-96100
28		62-96200

Ref.	Título	Código
	29	62-94101
	30	62-91001
	31	62-96100
	32	62-91120
	33	62-94101