

GRUPO CÁRTER

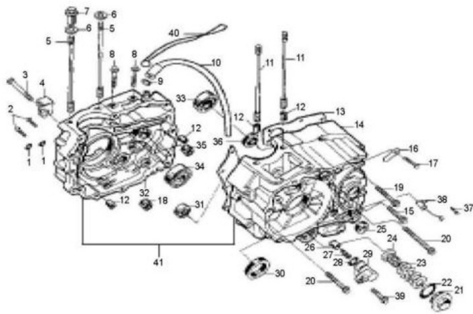

Rating: Not Rated Yet

Price:

Variant price modifier:

Base price with tax:

Price with discount:

Salesprice with discount:

Sales price:

Sales price without tax:

Discount:

Tax amount:

[Ask a question about this product](#)

Description	Ref.	Título	Código
	1		
	2	TORNILLO	
	3	TORNILLO M6 L=55	176-38004
	4	PLACA DE	176-19123
	5		176-11025
	6		

Ref.	Título	Código
7	TUERCA	176-12041
8	TORNILLO M6 L=28	
9		
10		
11		176-11024
12	PERNO D=10 L=14	176-38060
13	JUNTA DE CARTER	176-11010
14	CUERPO DEL SEMI CARTER	176-11003
15	TORNILLO	
16	PLACA	176-14017
17	TORNILLO M6 L=20	176-38014
18		
19	TORNILLO M6 L=20	176-38014
20	TORNILLO M6 L=95	
21	TAPA FILTRO DE ACEITE	176-12028
22	RETEN	
23	RESORTE	176-38115
24	MALLA FILTRO DE ACEITE	176-15029
25	RETEN DE ACEITE	
26		

Ref.	Título	Código
27	RESORTE	
28		176-800-40
29	PERNO	176-11032
30	RETEN DE ACEITE	
31		
32	CUERPO DEL SEMI CARTER DERECHO	176-11008
33		
34		
35		
36	RETEN DE ACEITE	
37	TORNILLO M4 L=18,A RANDELA ELASTICA	176-38068
38		176-27065
39	TORNILLO	176-38007
40	CABLE DEL MOTOR DE	176-27039
41	KIT DEL CARTER	176-50027

